



CENTRIFUGAL EXTRACT FANS

EcoAIR LC ECOWATT Series

ECOAIR LC ECOWATT



Range of 100mm domestic centrifugal extract fans for wall or ceiling installations, designed to work in accordance with two different operating modes:

- Continuously running operation which can be boosted with external or internal switch depending on the models.
- Intermittent operation with adjustable speed at installation.

Fitted with DC motors mounted on silent elastic blocks, the fans deliver incredibly silent running and exceptional performance with stylish features and very low power consumption significantly reducing energy costs.

5 models available

EcoAIR SLC: Continuous operation: the unit runs on trickle setting and can be boosted by an external switch. Intermittent operation: the unit runs on preset speed when external switch is turned on.

EcoAIR TLC: Continuous operation: Same operation than the SLC model, with an adjustable run-on timer, set to between 1 to 30 minutes, on the boost. Intermittent operation: The timer allows the fan to continue to operate for the selected period after the switch has been turned off.

EcoAIR HLC: Continuous operation: The boost operation is activated either by the adjustable integral humidity sensor or by an external switch both with timer. Intermittent operation: the humidistat causes the extractor to operate automatically when the humidity level in the room is higher than the set level, with the facility to override the hygrostat by means of an external switch. "Interval" functions also integrated.

EcoAIR MLC: Same operation than H model but using the internal pullcord instead of the external switch.

EcoAIR DLC: Continuous operation: The boost operation is activated by the PIR detector and continues to operate after the selected period set on the timer. Intermittent operation: The extractor starts automatically when a movement is detected by the PIR detector and continues to operate after the selected period set on the timer.

EcoAIR LC ECOWATT

230V 50/60Hz

IPX4 -Lp

+ Attributes



Centrifugal forward curved impeller

Centrifugal forward curved impeller, with an extremely low sound level.



Silent-elastic-blocks

Motor mounted on "Silentelastical- block" to prevent vibration and noise transmission.



Wall or ceiling installation



Different styles with the bars colours



Different styles with the bars colours

Interchangeable colour bars. 4 colours to match the decor of the room: blue, red, green and yellow.

+ Features

	SLC	TLC	HLC	MLC	DLC
DC MOTOR	●	●	●	●	●
CONTINUOUS OPERATION + BOOST	●	●	●	●	●
INTERMITENT OPERATION	●	●	●	●	●
ADJUSTABLE SPEED	●	●	●	●	●
ADJUSTABLE RUN-ON TIMER		1-30 min.	1-30 min.	1-30 min.	1-30 min.
ADJUSTABLE HUMIDISTAT			●	●	
PULLCORD				●	
PIR DETECTOR					●
BACKDRAFT SHUTTER*	●	●	●	●	●

* Supplied in the packaging. To fit on the fan when used as "intermitent operation".

+ Technical characteristics

Model		Maximum airflow		Voltage (V)	Maximum absorbed power (W)	SFP (W/m ² /h)	Sound pressure level* (dB(A))	IP/ Insulation	Weight (kg)
		(m ³ /h)	l/s						
EcoAIR LC	min. speed	15	4	230-50/60Hz	0,8	0,05	<20	IPX4 class II	0,57
	max. speed	60	17		5,6	0,09	32		

* Measured at 3m, at the maximum air volume, in free field condition.

+ Dimensions

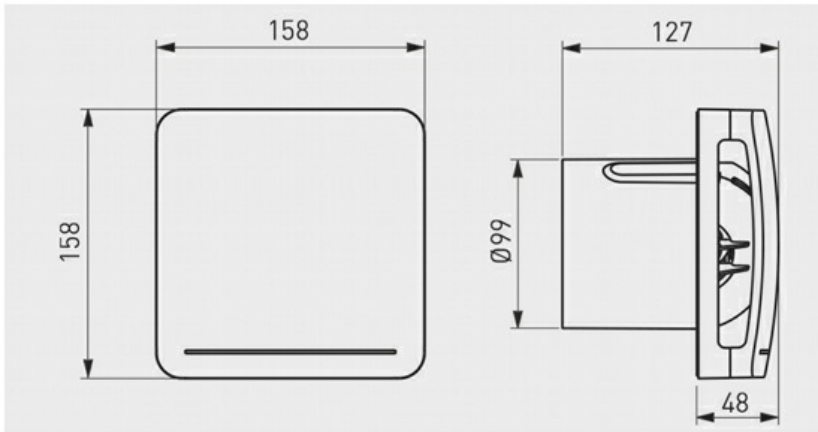

+ Curves

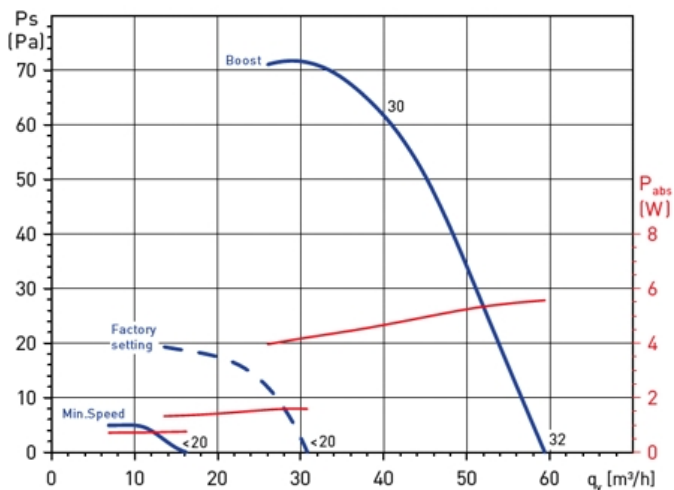

+ Mounting Accessories



GSA-100
Flexible aluminium ducting.



PER-100W
Back draft shutter.



GRA-70
Aluminium grille.